

SALES DRAWING

SALES DRAWING

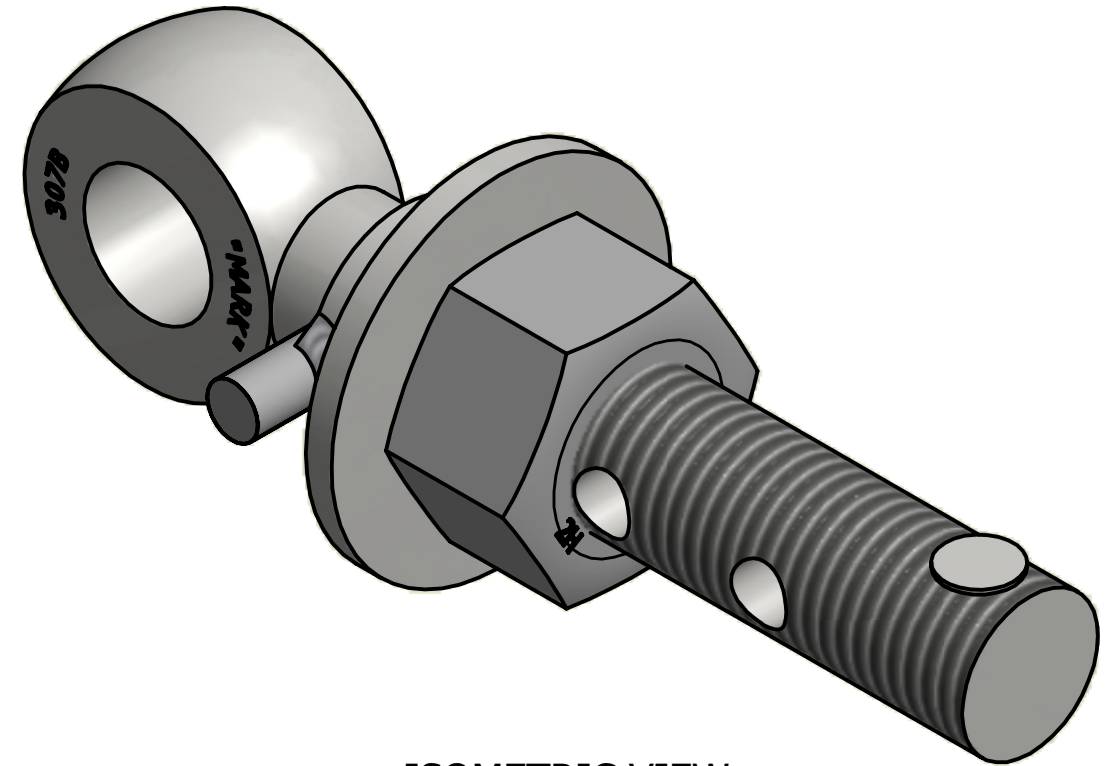

ISOMETRIC VIEW

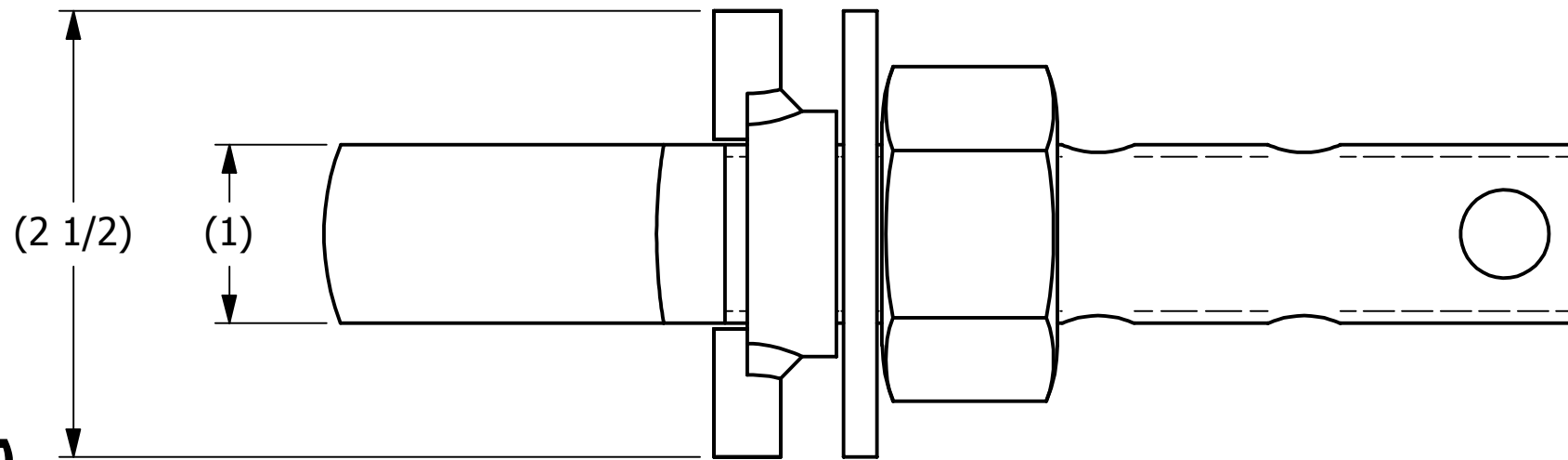
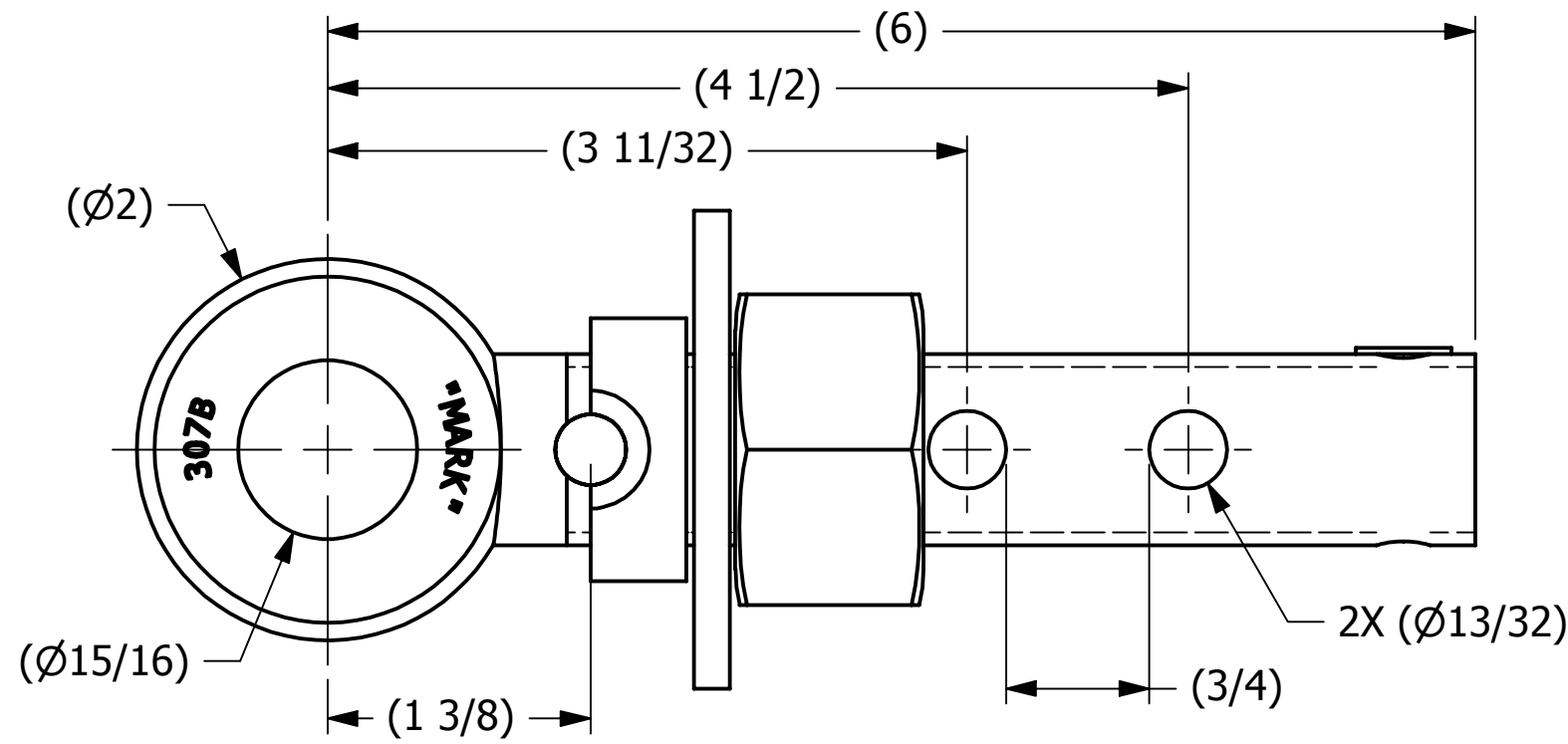

A	REH	6-17-10	ADDED NEW PART TO SYSTEM
REV	BY	DATE	DESCRIPTION

<small>UNLESS OTHERWISE SPECIFIED DIMENSIONAL TOLERANCES</small> FRACTIONAL: ±1/16 X.XX: ±.03 X.XXX: ±.015 ANGULAR: ±1° <small>DEBURR ALL SHARP EDGES. ALL MACHINED SURFACES TO HAVE A 125 RMS FINISH UNLESS NOTED OTHERWISE.</small> THIRD ANGLE PROJECTION	DRAWN BY:	REH
	CHECKED BY:	WRB
	PROTOTYPE BY:	REH
	PROTOTYPE DATE:	6/16/2010
	APPROVED FOR PRODUCTION BY:	
	PRODUCTION DATE:	

SALCO PRODUCTS, INC.		
PART NAME: EYEBOLT ASSEMBLY 1"X6"		
MATERIAL: CARBON STEEL		
PROJECT #: 100427	SHEET #: 1 OF 1	SCALE: 1:1
DRAWING #: B28936	PART #: EB16X2HATCP	

THIS PRINT, PROPERTY OF SALCO PRODUCTS INC., CONTAINS PROPRIETARY INFORMATION AND MUST NOT BE COPIED, REPRODUCED, OR USED DETRIMENTALLY TO OUR INTEREST.